

CS547A

Conductivity and Temperature Probe and A547 Interface

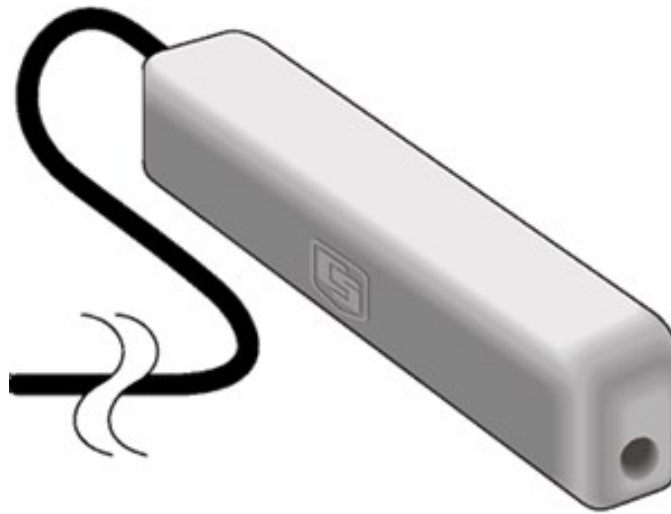

Guarantee

This equipment is guaranteed against defects in materials and workmanship. We will repair or replace products which prove to be defective during the guarantee period as detailed on your invoice, provided they are returned to us prepaid. The guarantee will not apply to:

- Equipment which has been modified or altered in any way without the written permission of Campbell Scientific
- Batteries
- Any product which has been subjected to misuse, neglect, acts of God or damage in transit.

Campbell Scientific will return guaranteed equipment by surface carrier prepaid. Campbell Scientific will not reimburse the claimant for costs incurred in removing and/or reinstalling equipment. This guarantee and the Company's obligation thereunder is in lieu of all other guarantees, expressed or implied, including those of suitability and fitness for a particular purpose. Campbell Scientific is not liable for consequential damage.

Please inform us before returning equipment and obtain a Repair Reference Number whether the repair is under guarantee or not. Please state the faults as clearly as possible, and if the product is out of the guarantee period it should be accompanied by a purchase order. Quotations for repairs can be given on request. It is the policy of Campbell Scientific to protect the health of its employees and provide a safe working environment, in support of this policy a "Declaration of Hazardous Material and Decontamination" form will be issued for completion.

When returning equipment, the Repair Reference Number must be clearly marked on the outside of the package. Complete the "Declaration of Hazardous Material and Decontamination" form and ensure a completed copy is returned with your goods. Please note your Repair may not be processed if you do not include a copy of this form and Campbell Scientific Ltd reserves the right to return goods at the customers' expense.

Note that goods sent air freight are subject to Customs clearance fees which Campbell Scientific will charge to customers. In many cases, these charges are greater than the cost of the repair.



Campbell Scientific Ltd,
80 Hathern Road,
Shepshed, Loughborough, LE12 9GX, UK
Tel: +44 (0) 1509 601141
Fax: +44 (0) 1509 270924
Email: support@campbellsci.co.uk
www.campbellsci.co.uk

About this manual

Please note that this manual was originally produced by Campbell Scientific Inc. primarily for the North American market. Some spellings, weights and measures may reflect this origin.

Some useful conversion factors:

Area: 1 in ² (square inch) = 645 mm ²	Mass: 1 oz. (ounce) = 28.35 g 1 lb (pound weight) = 0.454 kg
Length: 1 in. (inch) = 25.4 mm 1 ft (foot) = 304.8 mm 1 yard = 0.914 m 1 mile = 1.609 km	Pressure: 1 psi (lb/in ²) = 68.95 mb Volume: 1 UK pint = 568.3 ml 1 UK gallon = 4.546 litres 1 US gallon = 3.785 litres

In addition, while most of the information in the manual is correct for all countries, certain information is specific to the North American market and so may not be applicable to European users.

Differences include the U.S standard external power supply details where some information (for example the AC transformer input voltage) will not be applicable for British/European use. *Please note, however, that when a power supply adapter is ordered it will be suitable for use in your country.*

Reference to some radio transmitters, digital cell phones and aerials may also not be applicable according to your locality.

Some brackets, shields and enclosure options, including wiring, are not sold as standard items in the European market; in some cases alternatives are offered. Details of the alternatives will be covered in separate manuals.

Part numbers prefixed with a “#” symbol are special order parts for use with non-EU variants or for special installations. Please quote the full part number with the # when ordering.

Recycling information



At the end of this product's life it should not be put in commercial or domestic refuse but sent for recycling. Any batteries contained within the product or used during the products life should be removed from the product and also be sent to an appropriate recycling facility.

Campbell Scientific Ltd can advise on the recycling of the equipment and in some cases arrange collection and the correct disposal of it, although charges may apply for some items or territories.

For further advice or support, please contact Campbell Scientific Ltd, or your local agent.



Campbell Scientific Ltd, 80 Hathern Road, Shepshed, Loughborough, LE12 9GX,
UK Tel: +44 (0) 1509 601141 Fax: +44 (0) 1509 270924
Email: support@campbellsci.co.uk
www.campbellsci.co.uk

Safety

DANGER — MANY HAZARDS ARE ASSOCIATED WITH INSTALLING, USING, MAINTAINING, AND WORKING ON OR AROUND **TRIPODS, TOWERS, AND ANY ATTACHMENTS TO TRIPODS AND TOWERS SUCH AS SENSORS, CROSSARMS, ENCLOSURES, ANTENNAS, ETC.** FAILURE TO PROPERLY AND COMPLETELY ASSEMBLE, INSTALL, OPERATE, USE, AND MAINTAIN TRIPODS, TOWERS, AND ATTACHMENTS, AND FAILURE TO HEED WARNINGS, INCREASES THE RISK OF DEATH, ACCIDENT, SERIOUS INJURY, PROPERTY DAMAGE, AND PRODUCT FAILURE. TAKE ALL REASONABLE PRECAUTIONS TO AVOID THESE HAZARDS. CHECK WITH YOUR ORGANIZATION'S SAFETY COORDINATOR (OR POLICY) FOR PROCEDURES AND REQUIRED PROTECTIVE EQUIPMENT PRIOR TO PERFORMING ANY WORK.

Use tripods, towers, and attachments to tripods and towers only for purposes for which they are designed. Do not exceed design limits. Be familiar and comply with all instructions provided in product manuals. Manuals are available at www.campbellsci.eu or by telephoning +44(0) 1509 828 888 (UK). You are responsible for conformance with governing codes and regulations, including safety regulations, and the integrity and location of structures or land to which towers, tripods, and any attachments are attached. Installation sites should be evaluated and approved by a qualified engineer. If questions or concerns arise regarding installation, use, or maintenance of tripods, towers, attachments, or electrical connections, consult with a licensed and qualified engineer or electrician.

General

- Prior to performing site or installation work, obtain required approvals and permits. Comply with all governing structure-height regulations, such as those of the FAA in the USA.
- Use only qualified personnel for installation, use, and maintenance of tripods and towers, and any attachments to tripods and towers. The use of licensed and qualified contractors is highly recommended.
- Read all applicable instructions carefully and understand procedures thoroughly before beginning work.
- Wear a **hardhat** and **eye protection**, and take **other appropriate safety precautions** while working on or around tripods and towers.
- **Do not climb** tripods or towers at any time, and prohibit climbing by other persons. Take reasonable precautions to secure tripod and tower sites from trespassers.
- Use only manufacturer recommended parts, materials, and tools.

Utility and Electrical

- **You can be killed** or sustain serious bodily injury if the tripod, tower, or attachments you are installing, constructing, using, or maintaining, or a tool, stake, or anchor, come in **contact with overhead or underground utility lines.**
- Maintain a distance of at least one-and-one-half times structure height, or 20 feet, or the distance required by applicable law, **whichever is greater**, between overhead utility lines and the structure (tripod, tower, attachments, or tools).
- Prior to performing site or installation work, inform all utility companies and have all underground utilities marked.
- Comply with all electrical codes. Electrical equipment and related grounding devices should be installed by a licensed and qualified electrician.

Elevated Work and Weather

- Exercise extreme caution when performing elevated work.
- Use appropriate equipment and safety practices.
- During installation and maintenance, keep tower and tripod sites clear of un-trained or non-essential personnel. Take precautions to prevent elevated tools and objects from dropping.
- Do not perform any work in inclement weather, including wind, rain, snow, lightning, etc.

Maintenance

- Periodically (at least yearly) check for wear and damage, including corrosion, stress cracks, frayed cables, loose cable clamps, cable tightness, etc. and take necessary corrective actions.
- Periodically (at least yearly) check electrical ground connections.

WHILE EVERY ATTEMPT IS MADE TO EMBODY THE HIGHEST DEGREE OF SAFETY IN ALL CAMPBELL SCIENTIFIC PRODUCTS, THE CUSTOMER ASSUMES ALL RISK FROM ANY INJURY RESULTING FROM IMPROPER INSTALLATION, USE, OR MAINTENANCE OF TRIPODS, TOWERS, OR ATTACHMENTS TO TRIPODS AND TOWERS SUCH AS SENSORS, CROSSARMS, ENCLOSURES, ANTENNAS, ETC.

Table of contents

1. Introduction	1
2. Precautions	1
3. Initial inspection	1
4. QuickStart	1
5. Overview	4
5.1 EC sensor	5
5.2 Conductivity interface	5
6. Specifications	6
6.1 CS574A probe	6
6.2 Temperature sensor	7
6.3 A547 interface	7
7. Installation	8
7.1 Site selection	8
7.2 Mounting	8
7.3 Wiring	8
7.4 Programming	9
7.4.1 EC measurement	10
7.4.2 Ionization correction	10
7.4.3 Temperature measurement	10
7.4.4 Correct EC measurement for temperature errors	11
7.4.5 Output processing	11
8. Operation	12
8.1 Calibration	12
8.1.1 Conversion factors	12
8.1.2 Typical ranges	12
8.1.3 Factory calibration	12
8.1.4 Field calibration	12
8.2 Deriving a temperature compensation coefficient	13
8.3 Analysis of ionization-error correction	13

8.4 Schematics	14
9. Maintenance	15
Appendix A. Importing Short Cut code into CRBasic Editor	16

1. Introduction

The CS574A probe monitors the electrical conductivity (EC) and temperature of fresh water. It connects to a Campbell Scientific data logger using the A547 interface. This probe is compatible with most Campbell Scientific data loggers.

NOTE:

This manual provides information only for CRBasic data loggers. For retired Edlog data logger support, see an older manual at www.campbellsci.com/old-manuals .

2. Precautions

- READ AND UNDERSTAND the [Safety](#) section at the front of this manual.
- The CS574A and A547 are precision instruments. Please handle them with care.
- CAUTION: Rapid heating and cooling of the CS574A, such as leaving it in the sun and then submersing it in a cold stream, may cause irreparable damage.
- Do not use the CS574A with long cable lengths in an electrically noisy environment.

3. Initial inspection

- Upon receipt of the CS574A and A547, inspect the packaging and contents for damage. File damage claims with the shipping company.
- Immediately check package contents against the shipping documentation. Contact Campbell Scientific about any discrepancies.

4. QuickStart

A video that describes data logger programming using *Short Cut* is available at:

www.campbellsci.eu/videos/cr1000x-data-logger-getting-started-program-part-3.  *Short Cut* is an easy way to program your data logger to measure the sensor and assign data logger

wiring terminals. *Short Cut* is available as a download on www.campbellsci.eu.  It is included in installations of *LoggerNet*, *RTDAQ*, and *PC400*.

The following procedure also shows using *Short Cut* to program the CS574A.

1. Open *Short Cut* and click **Create New Program**.
2. Double-click the data logger model.
3. In the **Available Sensors and Devices** box, type CS574A or locate the sensor in the **Sensors > Water > Quality > CS547A Conductivity and Temperature Probe** folder. Double click on the **CS547A Conductivity and Temperature Probe**. Type the **Cell Constant Kc** (printed on the sensor label), **Lead Length in Feet**, and **Temperature Correction** ([Deriving a temperature compensation coefficient](#) (p. 13)). Temperature defaults to degree Celsius. This can be changed by clicking the **Deg C** box and selecting **Deg F**, for degrees Fahrenheit, or **K** for Kelvin.

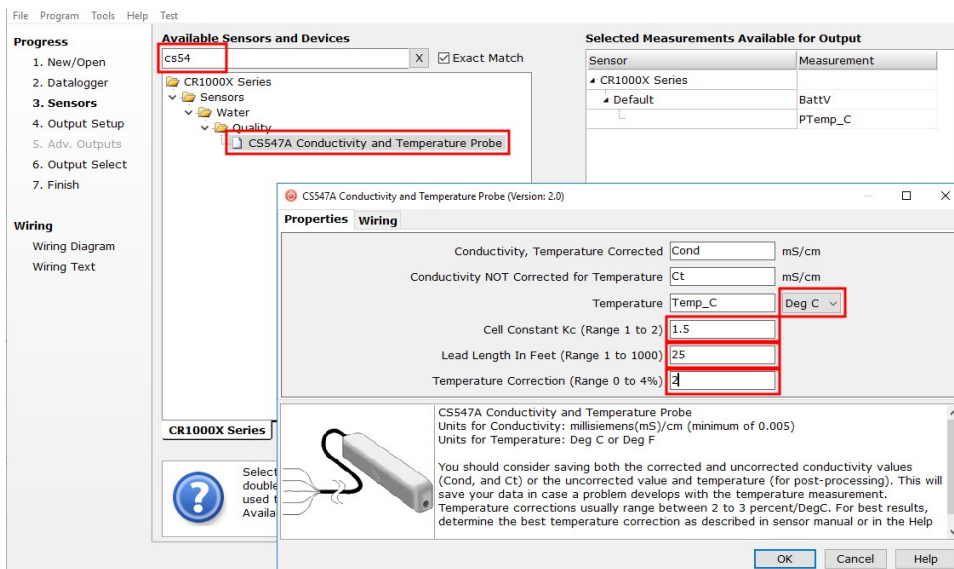

4. Click on the **Wiring** tab to see how the sensor is to be wired to the A547 and data logger.

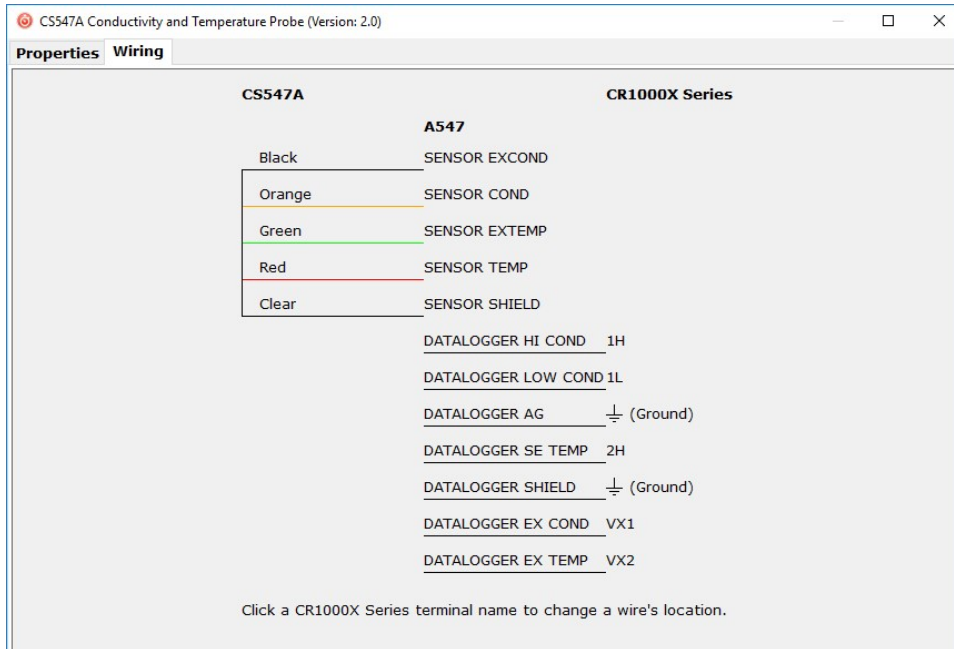

5. In **Output Setup**, type the scan rate, meaningful table names, and **Data Output Storage Interval**. Click **Next**.

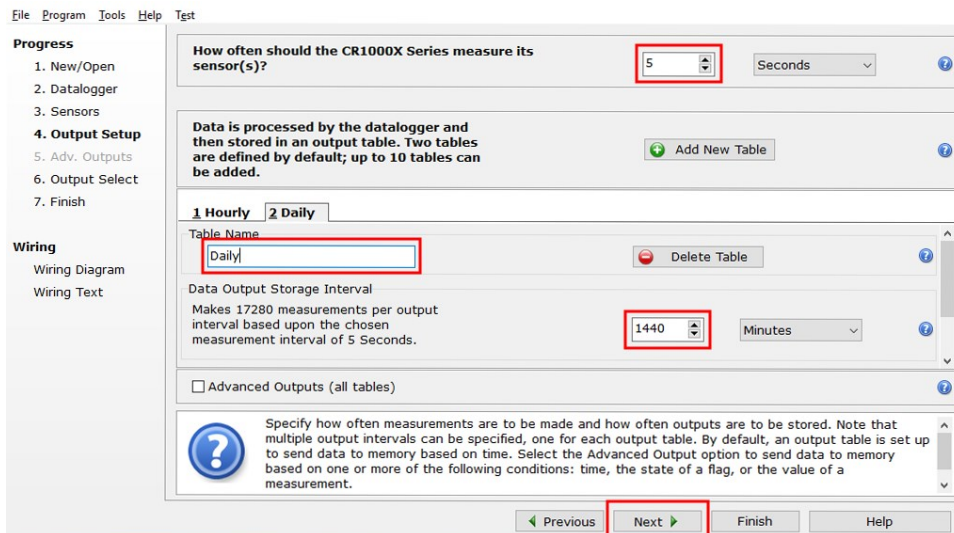

6. Select the measurement and its associated output option.

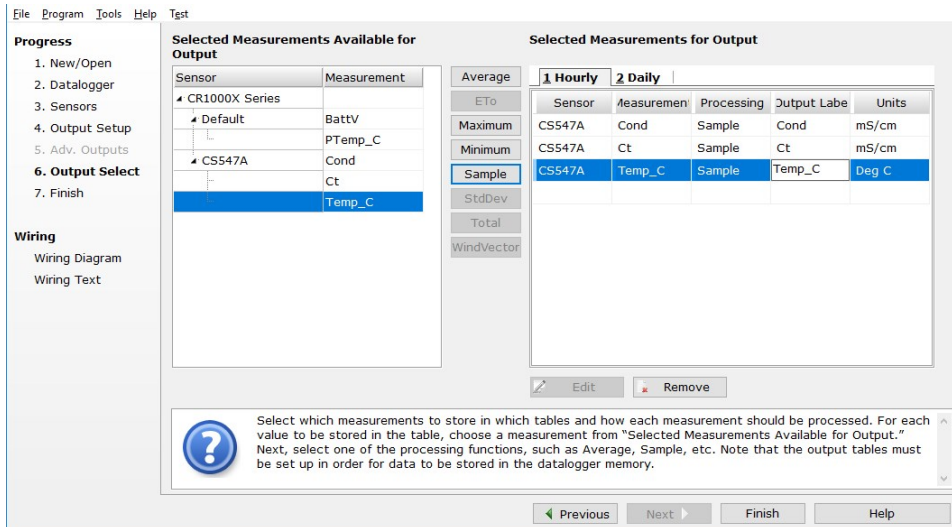

7. Click **Finish** and save the program. Send the program to the data logger if the data logger is connected to the computer.
8. If the sensor is connected to the data logger, check the output of the sensor in the data display in *LoggerNet*, *RTDAQ*, or *PC400* to make sure it is making reasonable measurements.

5. Overview

One A547 interface is required for each CS574A when used directly with the data logger; multiple CS574A probes can connect to one AM16/32B multiplexer and one A547 interface.

Electrical conductivity (EC) of a solution is a simple physical property, but measurements can be difficult to interpret. This manual instructs the user how to make EC measurements with the CS574A. Accuracy specifications apply to measurements of EC in water containing KCl, Na₂SO₄, NaHCO₃, and/or NaCl, which are typical calibration compounds, and to EC not yet compensated for temperature effects.

Statements made on methods of temperature compensation or estimating dissolved solids are included to introduce common ways of refining and interpreting data, but are not definitive. Authoritative sources to consult include the *USGS Water-Supply Paper 1473, The pH and Conductivity Handbook* published by OMEGA Engineering, physical chemistry texts, and other sources.

Features:

- Compatible with AM16/32-series multiplexers allowing measurement of multiple sensors
- Rounded ends facilitate installation and removal
- Easy to clean
- Corrosion resistant
- Weighted option available for stand-alone submersion
- Compatible with Campbell Scientific CRBasic data loggers: CR6, CR1000X, CR800-series, CR3000, CR1000

5.1 EC sensor

The CS574A consists of three stainless steel rings mounted in an epoxy tube (FIGURE 5-1 (p. 5)). Resistance of water in the tube is measured by excitation of the centre electrode with positive and negative voltage. This electrode configuration eliminates the ground looping problems associated with sensors in electrical contact with earth ground. Temperature is measured with a thermistor in a three-wire half-bridge configuration.

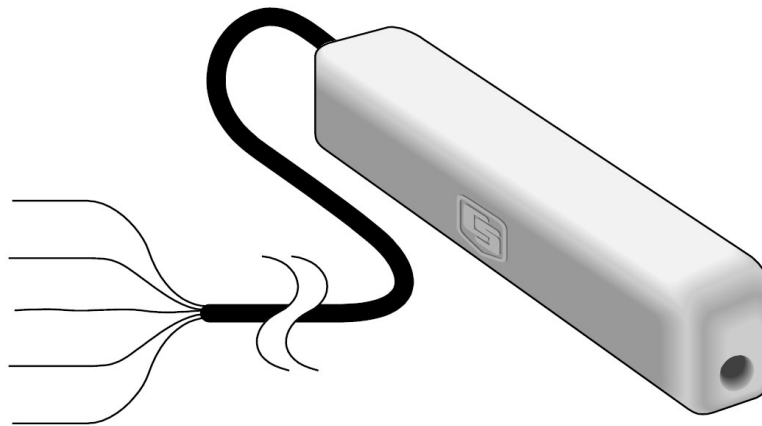

FIGURE 5-1. CS574A Conductivity and Temperature Probe

5.2 Conductivity interface

The A547 interface (FIGURE 5-2 (p. 6)) consists of blocking capacitors and bridge completion resistors housed in a metal case. Screw terminals are provided for connecting the data logger, and a water conductivity probe or multiplexer. Keep the interface in a non-condensing environment that is maintained within the temperature range of the unit. Typically, the A547 is housed in the data logger enclosure.

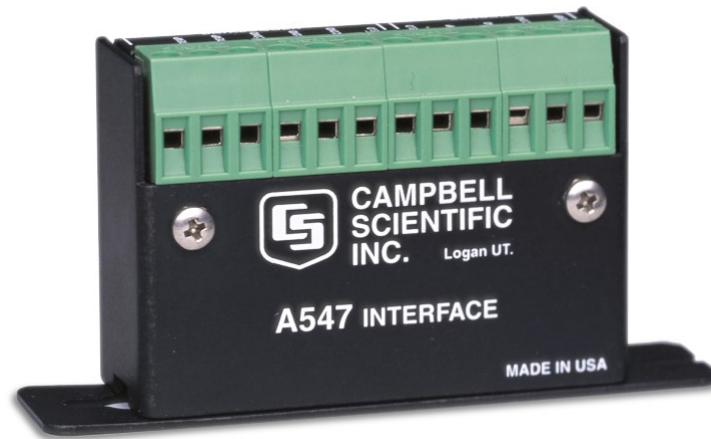

FIGURE 5-2. A547 Interface

6. Specifications

6.1 CS574A probe

Housing:	Epoxy
Length:	89 mm (3.5 in)
Width:	25.4 mm (1 in)
Height:	19 mm (0.75 in)
Minimum pipe ID in which CS574A fits:	28 mm (1.1 in)
Maximum cable length:	305 m (1000 ft). The sensor must be ordered with desired length as cable cannot be added to existing probes.
Depth rating:	305 m (1000 ft) maximum
pH range:	Solution pH of less than 3.0 or greater than 9.0 may damage the stainless steel housing.
Electrodes:	Passivated 316 SS with DC isolation capacitors.
Cell constant:	Individually calibrated. The cell constant (K_C) is found on a label near the termination of the cable.
Operating temperature range:	0 to 50 °C

EC range:	~ 0.005 to 7.0 mS/cm
EC measurement error	
Bridge measurement error:	<1%
Calibration error:	In KCl and Na ₂ SO ₄ , NaHCO ₃ , and NaCl standard solutions at 25 °C: ±5% of reading (0.44 to 7.0 mS/cm) ±10% of reading (0.005 to 0.44 mS/cm)
Ionization error of KCl and Na ⁺ solutions after correction:	< 2.0%, 0.45 to 7.0 mS/cm < 8.0%, 0.005 to 0.45 mS/cm
Weight with 4 ft cable:	120 g (4.2 oz)

6.2 Temperature sensor

Thermistor:	Betatherm 100K6A1
Range:	0 to 50 °C
Accuracy ¹	
Worst case:	±0.4 °C (–24 to 48 °C) ±0.9 °C (–35 to 50 °C)
Interchangeability error:	±0.10 °C (0 to 50 °C) ±0.20 °C at –10 °C ±0.30 °C at –20 °C ±0.40 °C at –30 °C ±0.50 °C at –40 °C
Steinhart-Hart equation error:	≤±0.01 °C (–35 to 50 °C)

¹Overall probe accuracy is a combination of thermistor interchangeability, bridge-resistor accuracy, and error of the Steinhart-Hart equation. Bridge resistors have 0.1% tolerance with a 10 ppm temperature coefficient. Interchangeability is the principle component error.

6.3 A547 interface

Length:	64 mm (2.5 in)
Height:	46 mm (1.8 in)
Width:	23 mm (0.9 in)

Weight:	45 g (2 oz)
Temperature rating:	-15 to 50 °C

7. Installation

If you are programming your data logger with *Short Cut*, skip [Wiring](#) (p. 8) and [Programming](#) (p. 9). *Short Cut* does this work for you. See [QuickStart](#) (p. 1) for a *Short Cut* tutorial.

7.1 Site selection

The CS574A measures the EC of water inside the hole running through the sensor, so detection of rapid changes in EC requires the probe be flushed continuously. To do this in flowing streams, simply orient the sensor parallel to the direction of flow. In stilling wells and ground wells, however, diffusion rate of ions limits the response time.

7.2 Mounting

The housing and sensor cable are made of water impervious, durable materials. Mount the probe so that it avoids contact with abrasives and moving objects. Because of slight positive buoyancy, either secure the sensor to a fixed or retractable object or use the weighted cable option.

The split mesh strain relief sleeve on the cable can minimize strain. The split mesh sleeve is recommended for cable lengths over 30 m (100 ft).

The A547 interface is usually mounted in the data logger enclosure.

7.3 Wiring

Wiring is shown in [FIGURE 7-1](#) (p. 9).

WARNING:

Wire the conductivity excitation and temperature excitation lines in different excitation ports or measurement errors will occur. If multiple CS574A/A547s are wired to one data logger, each conductivity excitation must use a separate excitation port. However, you can wire multiple temperature excitation lines into the same excitation port.

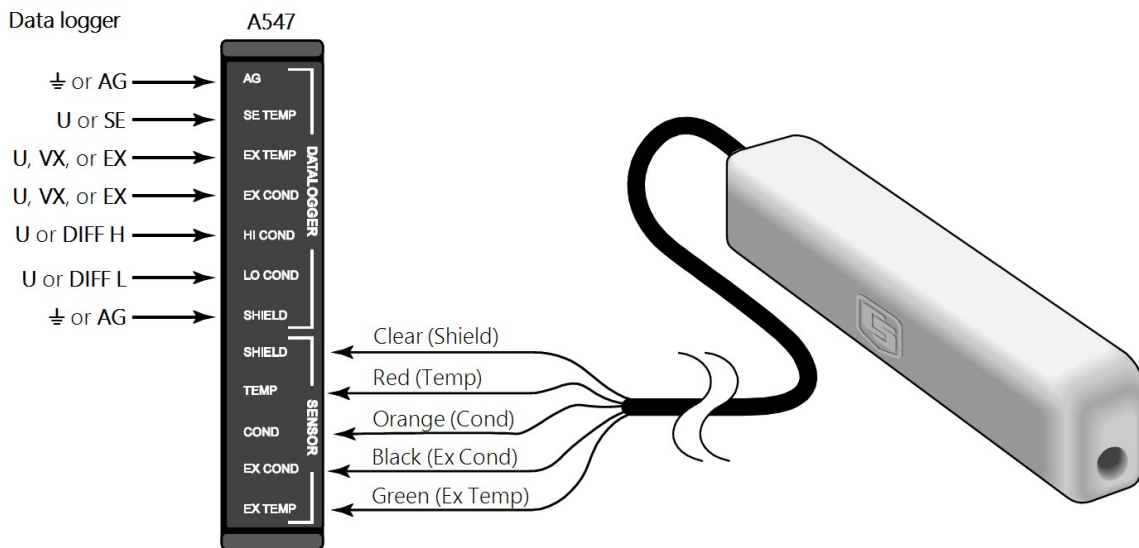

FIGURE 7-1. CS574A wiring diagram

7.4 Programming

Short Cut is the best source for up-to-date programming code for Campbell Scientific data loggers. If your data acquisition requirements are simple, you can probably create and maintain a data logger program exclusively with *Short Cut*. If your data acquisition needs are more complex, the files that *Short Cut* creates are a great source for programming code to start a new program or add to an existing custom program.

NOTE:

Short Cut cannot edit programs after they are imported and edited in *CRBasic Editor*.

A *Short Cut* tutorial is available in [QuickStart](#) (p. 1). If you wish to import *Short Cut* code into *CRBasic Editor* to create or add to a customized program, follow the procedure in [Importing Short Cut code into CRBasic Editor](#) (p. 16).

The data logger program needs to measure the EC, measure the internal temperature sensor, and correcting the EC measurement for resistance, ionization, and temperature errors.

Programming basics for CRBasic data loggers are in the following sections. Downloadable example programs are available at www.campbellsci.eu/downloads/cs547a-program-examples[↗]. Programming basics and programming examples for Edlog data loggers are provided at www.campbellsci.com/old-manuals[↗].

7.4.1 EC measurement

NOTE:

Older data loggers, such as the CR800-series and CR1000, use a different method to measure EC. Refer to the CR1000 example program at www.campbellsci.eu/downloads/cs547a-program-examples  for more information.

1. Measure the voltage output using the **BrFull()** CRBasic instruction. The **BrFull()** instruction has the following format:

```
BrFull ( Dest, Repts, Range, DiffChan, ExChan, MeasPEX, ExmV, RevEx, RevDiff,
        SettlingTime, fN1, Mult, Offset)
```

A typical **BrFull()** instruction follows:

```
BrFull (Rs, 1, mV5000, 1, VX1, 1, 2500, True, True, 450, 4000, -0.001, 1)
```

2. Convert voltage measurement to resistance (Eq. 1 (p. 10)):

$$R_s = (R_s / (1 - R_s)) \quad \text{Eq. 1}$$

Where R_s is the solution resistance.

3. Subtract the resistance error (Eq. 2 (p. 10)):

$$R_s = R_s - (C_length \times 0.000032 + 0.005) \quad \text{Eq. 2}$$

Where: C_length is the cable length in feet (printed on the sensor cable)

4. Calculate the EC (Eq. 3 (p. 10)):

$$C_t = (1/R_s) \times KC \quad \text{Eq. 3}$$

Where, C_t is EC without temperature correction, and KC is printed on the sensor label.

7.4.2 Ionization correction

The equation used to correct for ionization in the EC measurement depends on the EC value. For EC values less than 0.475 use Eq. 4 (p. 10) and use Eq. 5 (p. 10) for values greater than or equal to 0.475:

$$C_t = C_t \times 0.95031 - 0.00378 \quad \text{Eq. 4}$$

$$C_t = -0.02889 + (0.98614 \times C_t) + (0.02846 \times C_t^2) \quad \text{Eq. 5}$$

7.4.3 Temperature measurement

The **Therm107()** measurement instruction programs CRBasic data loggers to measure the CS574A internal temperature sensor. It applies a precise excitation voltage, makes a half-bridge

resistance measurement, and converts the result to temperature using the Steinhart-Hart equation. See Measurement and output linearization section in the 107 manual for more information. [Therm107\(\)](#) instruction and parameters are as follows:

[Therm107](#)(Dest, Repts, SEChan, VxChan, SettlingTime, Integ/fN1, Mult, Offset)

Set **Mult** to 1 and **Offset** to 0, which reports temperature as degree Celsius. If the sensor is in an electronically noisy environment, set the **Integ/fN1** to the 60 Hz or 50 Hz. Set the **SettlingTime** to 20000 to compensate for long cable lengths (> 91 m (300 ft)).

7.4.4 Correct EC measurement for temperature errors

Temperature of the sample solution can cause large errors in the EC measurement. [Eq. 6](#) (p. 11) corrects for temperature by assuming a linear relationship between temperature and EC. This method generally produces values within 2% to 3% of a measurement made at 25 °C.

$$\text{Cond} = (\text{Ct} \times 100) / ((\text{Temp_C} - 25) \times \text{TempCoef} + 100) \quad \text{Eq. 6}$$

Where Cond is EC in mS/cm corrected for temperature; Temp_C is the value returned by the [Therm107\(\)](#) instruction; and TempCoef is a temperature coefficient. The best corrections are made when the temperature coefficient is determined at a temperature near field conditions. See [Deriving a temperature compensation coefficient](#) (p. 13) for details on how to determine the temperature coefficient. If determining the temperature coefficient is not possible, use a value of 2% / °C as a rough estimate.

7.4.5 Output processing

Over large ranges, EC is not linear and it is recommended to use the Sample CRBasic instruction. In limited ranges, averaging measurements over time may be acceptable; this is accomplished by using the [Average](#) instruction in CRBasic. Convention requires that the temperature at the time of the measurement be reported.

8. Operation

8.1 Calibration

8.1.1 Conversion factors

1 S (Siemens) = 1 mho = 1/ohm

Although $\text{mS}\cdot\text{cm}^{-1}$ and $\mu\text{S}\cdot\text{cm}^{-1}$ are the commonly used units of EC, the SI base unit is $\text{S}\cdot\text{m}^{-1}$. The result of the example programs is $\text{mS}\cdot\text{cm}^{-1}$.

EC measurements can be used to estimate dissolved solids. For high accuracy, calibration to the specific stream is required. However, for rough estimates, values between 550 and 750 (mg/L)/(mS/cm) are typical with the higher values generally being associated with waters high in sulfate concentration (USGS Water-Supply Paper #1473, p. 99). A common practice is to multiply the EC in $\text{mS}\cdot\text{cm}^{-1}$ by 500 to produce ppm or mg/L.

8.1.2 Typical ranges

Single distilled water will have an EC of at least $0.001 \text{ mS}\cdot\text{cm}^{-1}$. ECs of melted snow usually range from 0.002 to $0.042 \text{ mS}\cdot\text{cm}^{-1}$. ECs of stream water usually range from 0.05 to $50.0 \text{ mS}\cdot\text{cm}^{-1}$, the higher value being close to the EC of sea water (USGS Water-Supply Paper 1473, p. 102).

8.1.3 Factory calibration

The CS574A is shipped with a cell constant calibrated in a 0.01 molal KCl solution at $25.0 \text{ }^\circ\text{C} \pm 0.05 \text{ }^\circ\text{C}$. The solution has an EC of $1.408 \text{ mS}/\text{cm}$.

8.1.4 Field calibration

The cell constant is a dimensional number expressed in units of cm^{-1} . The unit cm^{-1} is slightly easier to understand when expressed as $\text{cm}\cdot\text{cm}^{-2}$. Because it is dimensional, the cell constant as determined at any one standard, will change only if the physical dimensions inside the CS574A probe change. Error due to thermal expansion and contraction is negligible. Corrosion and abrasion, however, have the potential of causing significant errors.

A field calibration of the CS574A cell constant can be accomplished as follows:

1. Make a 0.01 molal KCL solution by dissolving 0.7456 g of reagent grade KCl in 1000 g of distilled water, or purchase a calibration solution.

2. Clean the probe thoroughly with the black nylon brush shipped with the CS574A and a small amount of soapy water. Rinse thoroughly with distilled water, dry thoroughly, and place in the KCl solution.
3. Connect the CS574A and A547 or probe and interface to the data logger using the wiring described in [Wiring](#) (p. 8). Program the data logger to make the field calibration. A downloadable calibration program is available at www.campbellsci.eu/downloads/cs547a-program-examples. 

The calibration solution temperature must be between 1 and 35 °C; a polynomial is used to correct for temperature errors within this range. The solution constant of 1.408 mS/cm (for prepared solution mentioned previously), is valid only for a 0.01 molal KCl solution.

8.2 Deriving a temperature compensation coefficient

1. Place the CS574A in a sample of the solution to be measured. Bring the sample and the probe to 25 °C.
2. Download the measurement program from www.campbellsci.eu/downloads/cs547a-program-examples  in the data logger and record the Ct at 25 °C. This number will be C₂₅ in the formula in Step 4.
3. Bring the solution and the probe to a temperature (t) near the temperature at which field measurements will be made. This temperature will be t (in °C) in the formula. Record Ct at the new temperature. This number will be C in the formula in Step 4.
4. Calculate the temperature coefficient (TC) using the following formula.

$$TC = 100 \bullet \frac{(C - C_{25})}{(t - 25) \bullet C_{25}} = \% / \bullet C$$

Enter TC in the appropriate variable as shown in the program segment in the example program available at www.campbellsci.eu/downloads/cs547a-program-examples. 

8.3 Analysis of ionization-error correction

FIGURE 8-1 (p. 14) and FIGURE 8-2 (p. 14) show the amount of correction applied by the example programs to compensate for ionization effects on the measurements. Also shown is an ideal correction. Factors were derived by measuring the standard solutions with values of 0.0234, 0.07, 0.4471, 0.7, 1.413, 2.070, 3.920, and 7.0 mS cm⁻¹.

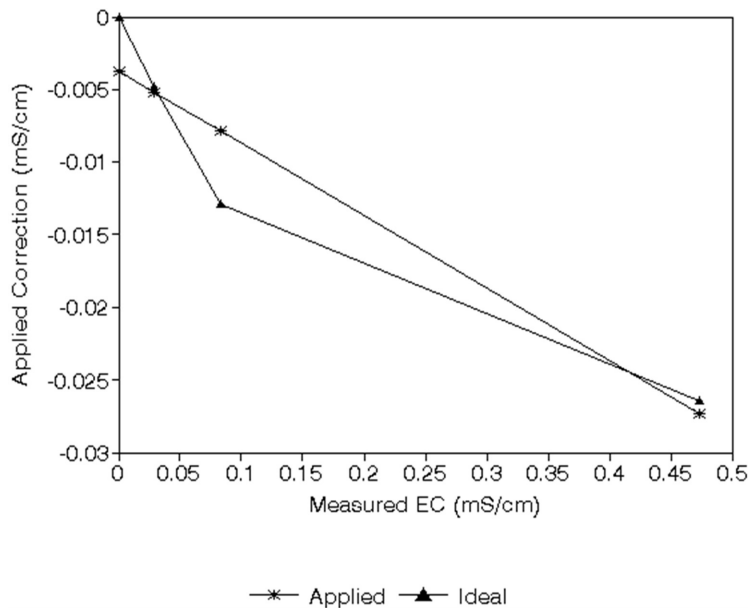

FIGURE 8-1. Plot of ideal and actual correction between 0 and 0.44 mS cm⁻¹

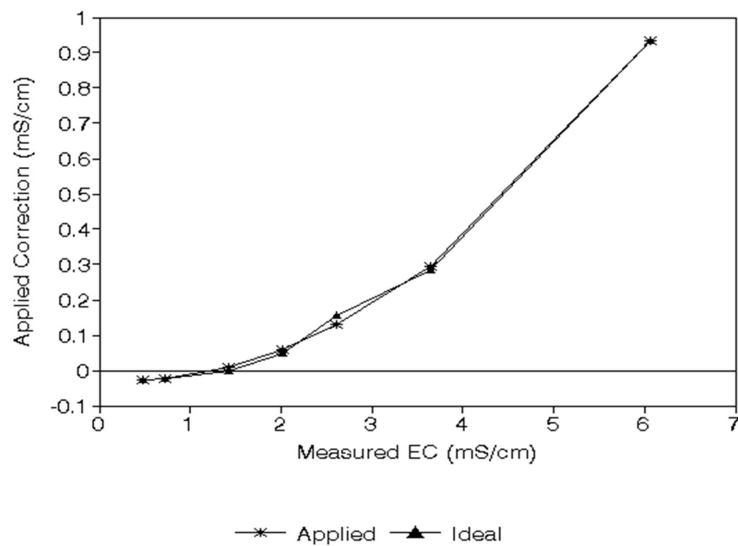

FIGURE 8-2. Plot of ideal and actual correction between 0.44 and 7.0 mS cm⁻¹

8.4 Schematics

The CS574A schematic is provided in [FIGURE 8-3](#) (p. 15), and the A547 schematic is provided in [FIGURE 8-4](#) (p. 15).

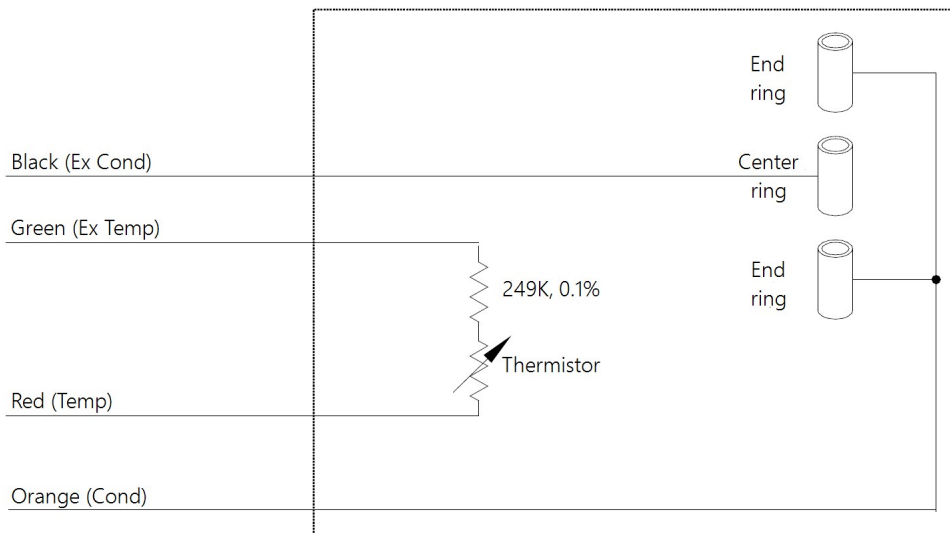

FIGURE 8-3. CS574A conductivity and temperature circuit diagram

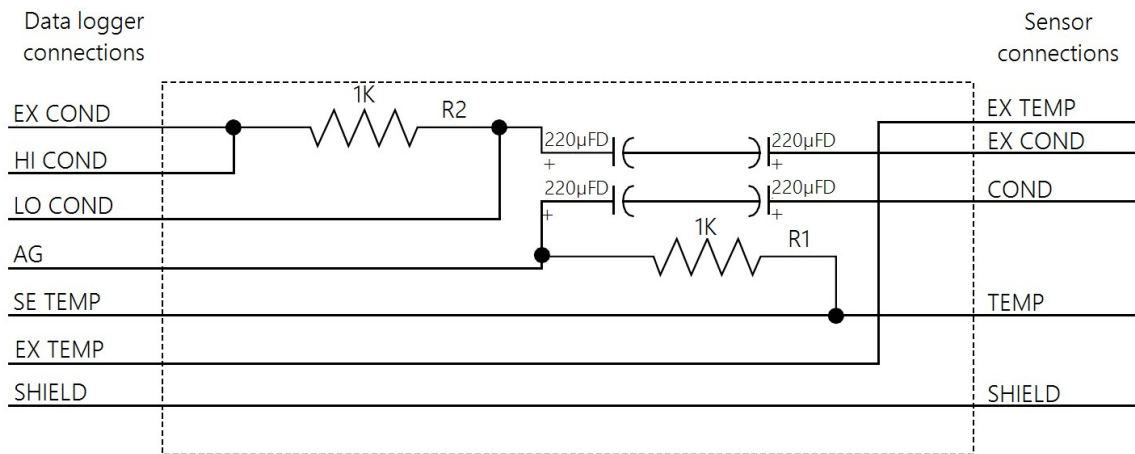

FIGURE 8-4. A547 Interface circuit diagram

9. Maintenance

Routine maintenance includes thoroughly cleaning the orifice of the CS574A probe with the black nylon brush provided and some soapy water. Rinse thoroughly.

Appendix A. Importing *Short Cut* code into *CRBasic Editor*

Short Cut creates a .DEF file that contains wiring information and a program file that can be imported into the *CRBasic Editor*. By default, these files reside in the C:\campbellsci\SCWin folder.

Import *Short Cut* program file and wiring information into *CRBasic Editor*:

1. Create the *Short Cut* program. After saving the *Short Cut* program, click the **Advanced** tab then the **CRBasic Editor** button. A program file with a generic name will open in CRBasic. Provide a meaningful name and save the CRBasic program. This program can now be edited for additional refinement.

NOTE:

Once the file is edited with *CRBasic Editor*, *Short Cut* can no longer be used to edit the program it created.

2. To add the *Short Cut* wiring information into the new CRBasic program, open the .DEF file located in the C:\campbellsci\SCWin folder, and copy the wiring information, which is at the beginning of the .DEF file.
3. Go into the CRBasic program and paste the wiring information into it.
4. In the CRBasic program, highlight the wiring information, right-click, and select **Comment Block**. This adds an apostrophe (') to the beginning of each of the highlighted lines, which instructs the data logger compiler to ignore those lines when compiling. The **Comment Block** feature is demonstrated at about 5:10 in the [CRBasic | Features](#) video .



Global Sales & Support Network

A worldwide network to help meet your needs



Campbell Scientific Regional Offices

Australia

Location: Garbutt, QLD Australia
Phone: 61.7.4401.7700
Email: info@campbellsci.com.au
Website: www.campbellsci.com.au

Brazil

Location: São Paulo, SP Brazil
Phone: 11.3732.3399
Email: vendas@campbellsci.com.br
Website: www.campbellsci.com.br

Canada

Location: Edmonton, AB Canada
Phone: 780.454.2505
Email: dataloggers@campbellsci.ca
Website: www.campbellsci.ca

China

Location: Beijing, P. R. China
Phone: 86.10.6561.0080
Email: info@campbellsci.com.cn
Website: www.campbellsci.com.cn

Costa Rica

Location: San Pedro, Costa Rica
Phone: 506.2280.1564
Email: info@campbellsci.com
Website: www.campbellsci.com

France

Location: Vincennes, France
Phone: 0033.0.1.56.45.15.20
Email: info@campbellsci.fr
Website: www.campbellsci.fr

Germany

Location: Bremen, Germany
Phone: 49.0.421.460974.0
Email: info@campbellsci.de
Website: www.campbellsci.de

India

Location: New Delhi, DL India
Phone: 91.11.46500481.482
Email: info@campbellsci.in
Website: www.campbellsci.in

South Africa

Location: Stellenbosch, South Africa
Phone: 27.21.8809960
Email: sales@campbellsci.co.za
Website: www.campbellsci.co.za

Spain

Location: Barcelona, Spain
Phone: 34.93.2323938
Email: info@campbellsci.es
Website: www.campbellsci.es

Thailand

Location: Bangkok, Thailand
Phone: 66.2.719.3399
Email: info@campbellsci.asia
Website: www.campbellsci.asia

UK

Location: Shepshed, Loughborough, UK
Phone: 44.0.1509.601141
Email: sales@campbellsci.co.uk
Website: www.campbellsci.co.uk

USA

Location: Logan, UT USA
Phone: 435.227.9120
Email: info@campbellsci.com
Website: www.campbellsci.com